

FKL Dimensional Drawing
Models: 15–600
Mount: Horizontal

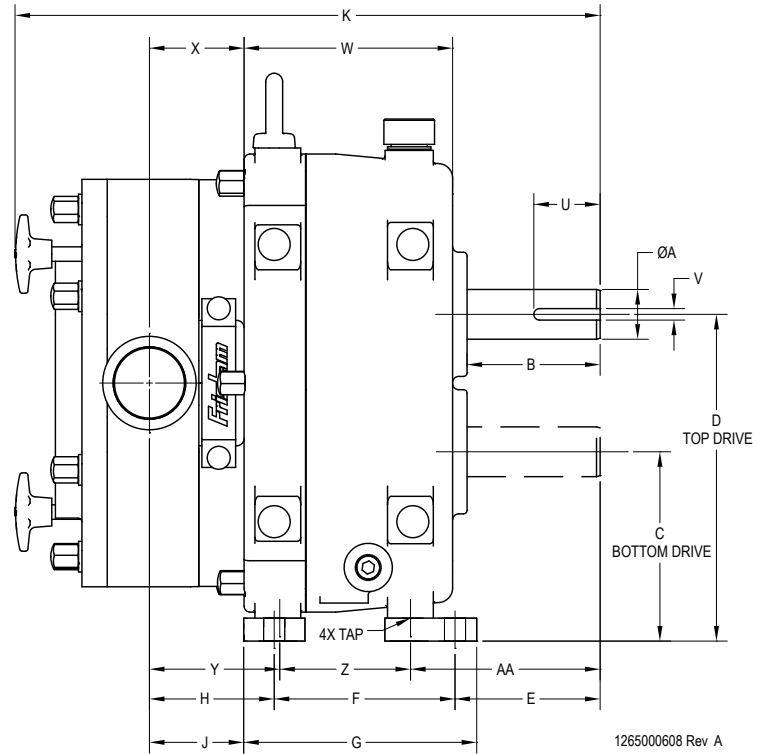
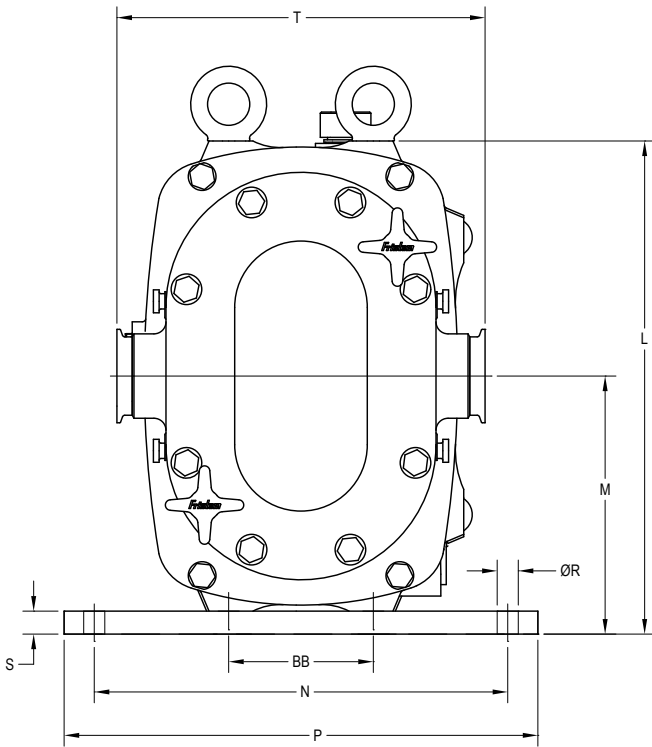

1265000608 Rev A

DIMENSIONS IN MILLIMETERS (INCHES)

PUMP MODEL	INLET/ OUTLET	ØA	B	C	D	E	F	G	H	J	K	L	M	N
FKL 15	1-1/2" CLAMP	3/4"	62.5 (2.46)	71.5 (2.81)	137.5 (5.41)	82 (3.23)	82 (3.23)	107 (4.21)	39 (1.54)	27 (1.06)	277 (10.91)	199.5 (7.86)	104.5 (4.11)	150 (5.91)
FKL 20	1-1/2" CLAMP	3/4"	62.5 (2.46)	71.5 (2.81)	137.5 (5.41)	82 (3.23)	82 (3.23)	107 (4.21)	39 (1.54)	27 (1.06)	280 (11.02)	199.5 (7.86)	104.5 (4.11)	150 (5.91)
FKL 25	1-1/2" CLAMP	1-1/4"	61 (2.40)	93.5 (3.68)	173.5 (6.83)	76 (2.99)	117 (4.61)	155 (6.10)	84 (3.31)	65 (2.56)	358 (14.09)	254.5 (10.02)	133.5 (5.26)	219 (8.62)
FKL 50	2-1/2" CLAMP	1-3/8"	73 (2.87)	102.5 (4.04)	192.5 (7.58)	120.5 (4.74)	85 (3.35)	136 (5.35)	88 (3.46)	63 (2.48)	391 (15.39)	282.5 (11.12)	147.5 (5.81)	240 (9.45)
FKL 75	2-1/2" CLAMP	1-5/8"	108 (4.25)	157 (6.18)	271 (10.67)	118 (4.65)	150 (5.91)	193 (7.60)	103.5 (4.07)	78 (3.07)	483 (19.02)	409 (16.10)	214 (8.43)	343 (13.50)
FKL 150	3" CLAMP	1-3/4"	99.5 (3.92)	171 (6.73)	291 (11.46)	114 (4.49)	177.5 (6.99)	227.5 (8.96)	111.5 (4.39)	86.5 (3.40)	521 (20.51)	443 (17.44)	231 (9.09)	364 (14.33)
FKL 205	4" CLAMP	2-1/4"	116 (4.57)	174.5 (6.87)	323 (12.72)	143 (5.63)	182 (7.17)	233 (9.17)	113 (4.45)	87.5 (3.44)	577 (22.72)	478.5 (18.84)	249 (9.80)	381 (15.00)
FKL 250	4" CLAMP	2-1/2"	122 (4.80)	194.5 (7.66)	357 (14.06)	129.5 (5.10)	215 (8.46)	265 (10.43)	123 (4.84)	98 (3.86)	604 (23.78)	532.5 (20.96)	276 (10.87)	381 (15.00)
FKL 400	6" CLAMP	2-7/8"	129.5 (5.10)	209.5 (8.25)	385.5 (15.18)	127 (5.00)	234 (9.21)	284.5 (11.20)	107 (4.21)	82 (3.23)	661.5 (26.05)	569.5 (22.42)	297.5 (11.71)	432 (17.01)
FKL 580*	6" CLAMP	100 (3.94)	141 (5.55)	235 (9.27)	455 (17.93)	208 (8.19)	204 (8.03)	255 (10.03)	173 (6.80)	148 (5.81)	777 (30.60)	681 (26.81)	345 (13.58)	500 (19.69)
FKL 600*	6" CLAMP	100 (3.94)	141 (5.55)	235 (9.27)	455 (17.93)	208 (8.19)	204 (8.03)	255 (10.03)	197 (7.75)	172 (6.77)	801 (31.54)	681 (26.81)	345 (13.58)	500 (19.69)

DIMENSIONS IN MILLIMETERS (INCHES)

PUMP MODEL	INLET/ OUTLET	P	ØR	S	T	U	V	W	X	Y	Z	AA	BB	TAP
FKL 15	1-1/2" CLAMP	170 (6.69)	10.5 (0.41)	9.5 (0.37)	173 (6.81)	50 (1.97)	4.8 (0.19)	107 (4.21)	33 (1.30)	60 (2.36)	61.5 (2.42)	81.5 (3.21)	58 (2.28)	M8 X 1.25"
FKL 20	1-1/2" CLAMP	170 (6.69)	10.5 (0.41)	9.5 (0.37)	173 (6.81)	50 (1.97)	4.8 (0.19)	107 (4.21)	33 (1.30)	60 (2.36)	61.5 (2.42)	81.5 (3.21)	58 (2.28)	M8 X 1.25"
FKL 25	1-1/2" CLAMP	241 (9.49)	11 (0.43)	12.5 (0.50)	198 (7.80)	33 (1.30)	6.4 (0.25)	137 (5.39)	93 (3.78)	69.5 (2.74)	96 (3.78)	88 (3.46)	84 (3.31)	M10 X 1.5"
FKL 50	2-1/2" CLAMP	280 (11.02)	13.5 (0.53)	12.5 (0.50)	285 (11.22)	55 (2.17)	7.9 (0.31)	141 (5.55)	67.5 (2.66)	94.5 (3.72)	85 (3.35)	114 (4.49)	96 (3.78)	M10 X 1.5"
FKL 75	2-1/2" CLAMP	393 (15.47)	17.5 (0.69)	19 (0.75)	306 (12.05)	55 (2.17)	9.5 (0.38)	173 (6.81)	78.5 (3.09)	103.5 (4.07)	115 (4.53)	153 (6.02)	120 (4.72)	M16 X 2.0"
FKL 150	3" CLAMP	414 (16.30)	17.5 (0.69)	19 (0.75)	326 (12.83)	61 (2.40)	9.5 (0.38)	184 (7.24)	96.5 (3.80)	123.5 (4.85)	121 (4.76)	158.5 (6.24)	121 (4.76)	M16 X 2.0"
FKL 205	4" CLAMP	419 (16.50)	17.5 (0.69)	19 (0.75)	344 (13.54)	75 (2.95)	9.5 (0.38)	222 (8.74)	88.5 (3.48)	126.5 (4.98)	155 (6.1)	156.5 (6.16)	182 (7.17)	M16 X 2.0"
FKL 250	4" CLAMP	419 (16.50)	17.5 (0.69)	19 (0.75)	377 (14.84)	65 (2.56)	15.9 (0.63)	234 (9.21)	106.5 (4.19)	144.5 (5.69)	172 (6.77)	151 (5.94)	182 (7.17)	M16 X 2.0"
FKL 400	6" CLAMP	482 (18.98)	22 (0.88)	25.5 (1.00)	499.5 (19.66)	80 (3.15)	19 (0.75)	265 (10.43)	88.5 (3.48)	127.5 (5.02)	193 (7.60)	208 (8.19)	208 (8.19)	M20 X 2.5"
FKL 580*	6" CLAMP	540 (21.25)	22 (0.88)	25.5 (1.00)	704 (27.72)	135 (5.31)	28 (1.10)	254 (10.00)	148 (5.83)	173 (6.81)	204 (8.03)	209 (8.23)	403 (15.87)	M20 X 2.5"
FKL 600*	6" CLAMP	540 (21.25)	22 (0.88)	25.5 (1.00)	707 (27.83)	135 (5.31)	28 (1.10)	254 (10.00)	172 (6.77)	197 (7.76)	204 (8.03)	209 (8.23)	403 (15.87)	M20 X 2.5"

* Models are not available in split gearbox design. Please visit www.fristam.com/usa for original design model drawings.

FKL Dimensional Drawing
Models: 15–600
Mount: Vertical

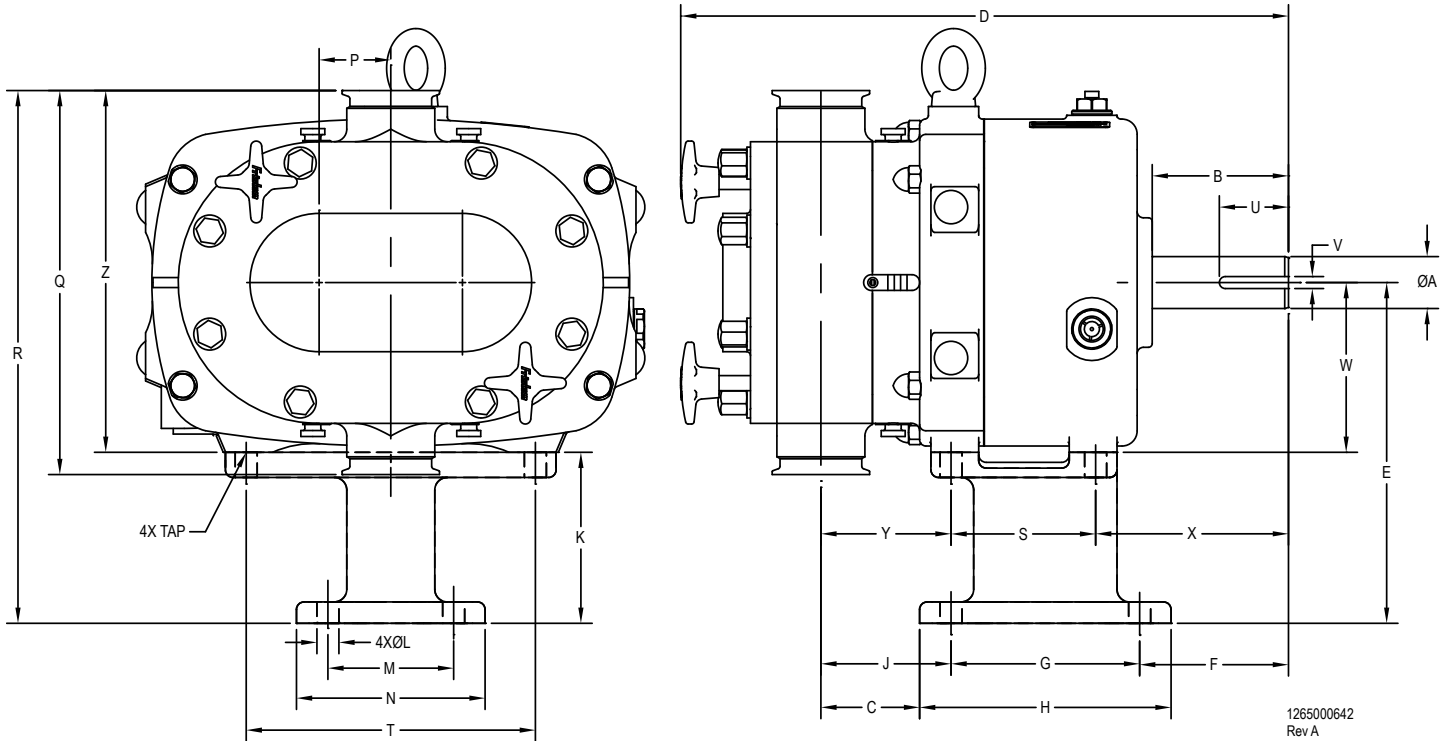

1265000642
Rev A

PUMP MODEL	INLET / OUTLET	DIMENSIONS IN MILLIMETERS (INCHES)										
		ØA	B	C	D	E	F	G	H	J	K	ØL
FKL 15	1-1/2" CLAMP	3/4"	62.5 (2.46)	30 (1.17)	277 (10.91)	141 (5.55)	82 (3.23)	82 (3.23)	100 (3.94)	39 (1.53)	78 (3.07)	9 (0.35)
FKL 20	1-1/2" CLAMP	3/4"	62.5 (2.46)	30 (1.17)	280 (11.02)	141 (5.55)	82 (3.23)	82 (3.23)	100 (3.94)	39 (1.53)	78 (3.07)	9 (0.35)
FKL 25	1-1/2" CLAMP	1-1/4"	61 (2.40)	66 (2.60)	358 (14.09)	174 (6.85)	76 (3.00)	117 (4.61)	153 (6.02)	84 (3.31)	88 (3.46)	11 (0.43)
FKL 50	2-1/2" CLAMP	1-3/8"	73 (2.87)	60.5 (2.38)	391 (15.39)	192 (7.56)	113 (4.46)	100 (3.94)	140 (5.51)	80.5 (3.17)	94 (3.70)	13.5 (0.53)
FKL 75	2-1/2" CLAMP	1-5/8"	108 (4.25)	78.5 (3.09)	483 (19.02)	271 (10.67)	118.5 (4.66)	150 (5.91)	200 (7.87)	103.5 (4.07)	136 (5.35)	17.5 (0.69)
FKL 150	3" CLAMP	1-3/4"	99.5 (3.92)	87.5 (3.44)	521 (20.51)	291 (11.46)	115.5 (4.55)	175 (6.89)	225 (8.86)	113 (4.44)	141 (5.55)	17.5 (0.69)
FKL 205	4" CLAMP	2-1/4"	116 (4.57)	88 (3.46)	577 (22.72)	323 (12.72)	143 (5.63)	182 (7.17)	232 (9.13)	113 (4.44)	163 (6.42)	17.5 (0.69)
FKL 250	4" CLAMP	2-1/2"	122 (4.80)	99.5 (3.92)	604 (23.78)	357.5 (14.07)	129.5 (5.10)	215 (8.46)	262 (10.31)	123 (4.84)	195 (7.68)	17.5 (0.69)
FKL 400	6" CLAMP	2-7/8"	129.5 (5.10)	-	661.5 (26.04)	-	-	-	-	-	-	-
FKL 580*	6" CLAMP	100 (3.94)	141 (5.55)	-	777 (30.60)	-	-	-	-	-	-	-
FKL 600*	6" 300# FLANGE	100 (3.94)	141 (5.55)	-	801 (31.54)	-	-	-	-	-	-	-

PUMP MODEL	M	N	P	Q	R	S	T	TAP	U	V	W	X	Y	Z	WEIGHT
FKL 15	88 (3.46)	105 (4.13)	33 (1.30)	173 (6.81)	227.5 (8.96)	61.5 (2.42)	102 (4.02)	M8X1.25	50 (1.97)	4.8 (0.19)	63 (2.48)	82 (3.22)	60 (2.36)	149.5 (5.89)	19.5 kg (43 lbs)
FKL 20	88 (3.46)	105 (4.13)	33 (1.30)	173 (6.81)	227.5 (8.96)	61.5 (2.42)	102 (4.02)	M8X1.25	50 (1.97)	4.8 (0.19)	63 (2.48)	82 (3.22)	60 (2.36)	149.5 (5.89)	22 kg (48.5 lbs)
FKL 25	122 (4.80)	158 (6.22)	40 (1.57)	198 (7.80)	273 (10.76)	93 (3.66)	146 (5.75)	M10X1.5	33 (1.30)	6.4 (0.25)	86 (3.39)	88 (3.47)	96 (3.78)	185 (7.29)	TBD
FKL 50	100 (3.94)	140 (5.51)	45 (1.77)	285 (11.22)	334.5 (13.17)	85 (3.35)	160 (6.3)	M10X1.5	55 (2.17)	7.9 (0.31)	98 (3.86)	114.5 (4.50)	94.5 (3.72)	240.5 (9.47)	65 kg (143 lbs)
FKL 75	100 (3.94)	150 (5.91)	57 (2.24)	306 (12.05)	424 (16.68)	115 (4.53)	230 (9.06)	M16X2	55 (2.17)	9.5 (0.38)	135 (5.31)	153.5 (6.04)	103.5 (4.07)	288 (11.33)	140 kg (308.5 lbs)
FKL 150	130 (5.12)	180 (7.09)	60 (2.36)	326 (12.83)	454 (17.88)	121 (4.76)	240 (9.45)	M16X2	61 (2.40)	9.5 (0.38)	150 (5.91)	158.5 (6.24)	123.5 (4.86)	313 (12.33)	182 kg (401 lbs)
FKL 205	212 (8.35)	262 (10.31)	74 (2.92)	344 (13.54)	495 (19.48)	155 (6.10)	279.5 (11.00)	M16X2	75 (2.95)	12.7 (0.50)	160 (6.30)	156.5 (6.17)	126.5 (4.98)	332 (13.07)	TBD
FKL 250	215 (8.46)	262 (10.31)	81 (3.20)	377 (14.84)	546 (21.49)	172 (6.77)	333.5 (13.13)	M16X2	66 (2.56)	15.9 (0.63)	162.5 (6.40)	151 (5.95)	144.5 (5.69)	351 (13.81)	TBD
FKL 400	-	-	88 (3.46)	499.5 (19.66)	-	193 (7.60)	348 (13.70)	M20X2.5	80 (3.15)	19 (0.75)	188 (7.40)	172.5 (6.79)	127.5 (5.02)	438 (17.23)	TBD
FKL 580*	-	-	110 (4.33)	704 (27.72)	-	204 (8.03)	540 (21.26)	M20X2.5	135 (5.31)	28 (1.10)	223 (8.78)	209 (8.21)	173 (6.80)	575 (22.64)	696.5 kg (1536 lbs)
FKL 600*	-	-	110 (4.33)	707 (27.83)	-	204 (8.03)	540 (21.26)	M20X2.5	135 (5.31)	28 (1.10)	223 (8.78)	209 (8.21)	197 (7.75)	576.5 (1270)	742 kg (1636 lbs)

* Models are not available in split gearbox design. Please visit www.fristam.com/usa for original design model drawings.

FKL Dimensional Drawing

Models: 50–400

Mount: Vertical w/ Rectangular Inlet

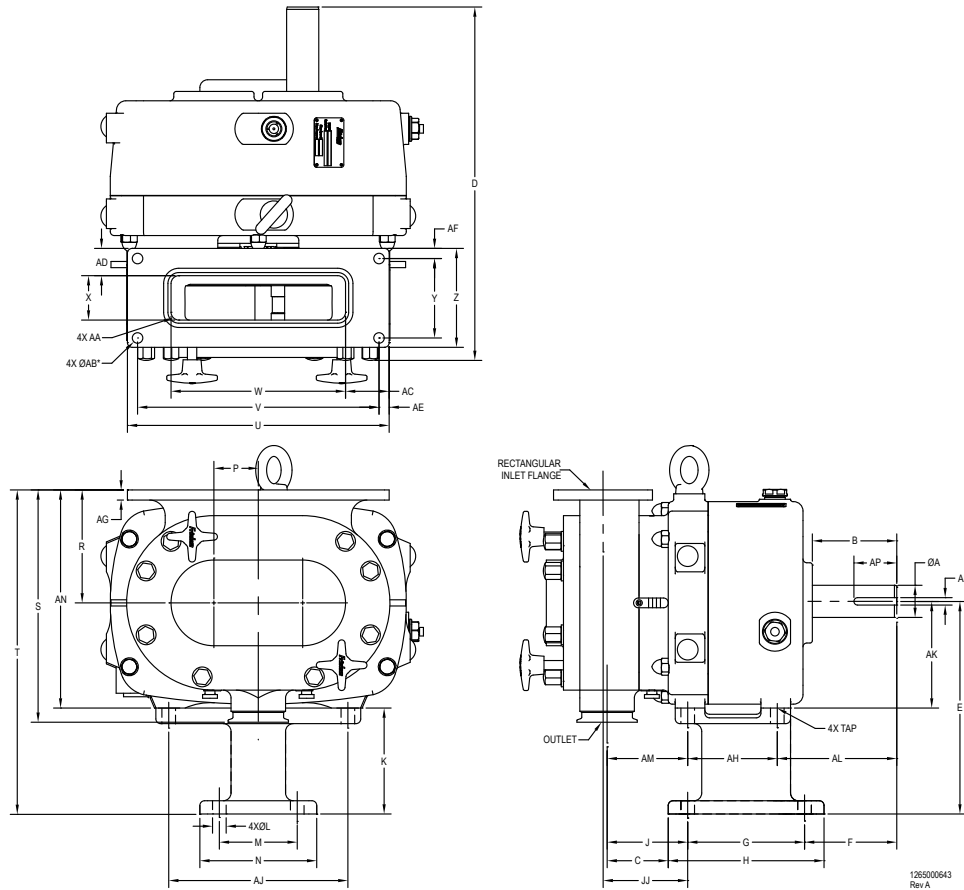

DIMENSIONS IN MILLIMETERS (INCHES)

PUMP MODEL	OUTLET	ØA	B	C	D	E	F	G	H	J	JJ	K	ØL	M	N	P	R	S	T	U	V
FKL 50	2-1/2" CLAMP	1-3/8"	73 (2.87")	60.5 (2.38")	391 (15.39")	192 (7.56")	113 (4.46")	100 (3.94")	140 (5.51")	80.5 (3.17")	88 (3.46")	94 (3.70")	13.5 (0.53")	100 (3.94")	140 (5.51")	45 (1.77")	106 (4.17")	249 (9.80")	298 (11.73")	305 (12.01")	273 (10.75")
FKL 75	2-1/2" CLAMP	1-5/8"	108 (4.25")	78.5 (3.09")	483 (19.02")	271 (10.68")	118.5 (4.66")	150 (5.91")	200 (7.87")	103.5 (4.07")	105 (4.13")	136 (5.35")	17.5 (0.69")	100 (3.94")	150 (5.91")	57 (2.24")	145 (5.71")	298 (11.72")	416 (16.38")	336 (13.23")	310 (12.20")
FKL 150	3" CLAMP	1-3/4"	99.5 (3.92")	87.5 (3.45")	521 (20.51")	291 (11.46")	115.5 (4.54")	175 (6.89")	225 (8.86")	113 (4.44")	107 (4.22")	141 (5.55")	17.5 (0.69")	130 (5.12")	180 (7.09")	60 (2.36")	157 (6.18")	320 (12.60")	448 (17.64")	387 (15.24")	355 (13.98")
FKL 205	4" CLAMP	2-1/4"	116 (4.57")	88 (3.46")	577 (22.72")	323 (12.72")	143 (5.63")	182 (7.17")	232 (9.13")	113 (4.44")	113 (4.44")	163 (6.42")	17.5 (0.69")	212 (8.35")	262 (10.31")	74 (2.92")	163 (6.42")	335 (13.19")	486 (19.13")	457 (17.99")	425 (16.73")
FKL 250	4" CLAMP	2-1/2"	122 (4.80")	99.5 (3.92")	604 (23.78")	357.5 (14.07")	129.5 (5.10")	215 (8.46")	262 (10.31")	123 (4.84")	122.5 (4.82")	195 (7.68")	17.5 (0.69")	215 (8.46")	262 (10.31")	81 (3.20")	181 (7.13")	369 (14.54")	538.5 (21.20")	457 (17.99")	425 (16.73")
FKL 400*	6" CLAMP	2-7/8"	129.5 (5.10")	-	637 (25.08")	-	-	-	-	-	-	-	-	-	-	88 (3.46")	243 (9.57")	493 (19.41")	-	505 (19.88")	469.5 (18.48")

126500643
Rev A

PUMP MODEL	W	X	Y	Z	AA	ØAB	AC	AD	AE	AF	AG	AH	AJ	TAP	AK	AL	AM	AN	AP	AR	WEIGHT
FKL 50	171 (6.73")	44 (1.73")	48 (1.89")	79 (3.11")	R6 (0.24")	13.5 (0.53")	67 (2.64")	17 (0.67")	16 (0.63")	15.5 (0.61")	13 (0.51")	85 (3.35")	160 (6.30")	M10X1.5	98 (3.86")	114.5 (4.50")	94.5 (3.72")	204 (8.03")	55 (2.17")	7.9 (0.31")	66 kg 145 lbs
FKL 75	224 (8.82")	57 (2.24")	102 (4.02")	127 (5.00")	R10 (0.39")	13.5 (0.53")	56 (2.20")	35 (1.38")	13 (0.51")	13 (0.51")	13 (0.51")	115 (4.53")	230 (9.06")	M16X2	135 (5.31")	153.5 (6.04")	103.5 (4.07")	280 (11.02")	55 (2.17")	9.5 (0.38")	141.5 kg 312.5 lbs
FKL 150	235 (9.25")	75 (2.95")	84 (3.31")	118 (4.65")	R10 (0.39")	13.5 (0.53")	76 (2.99")	21.5 (0.85")	16 (0.67")	17 (0.67")	13 (0.51")	121 (4.76")	240 (9.45")	M16X2	150 (5.91")	158.5 (6.24")	123.5 (4.86")	307 (12.09")	61 (2.40")	9.5 (0.38")	183.5 kg 405 lbs
FKL 205	279 (10.98")	99 (3.90")	111 (4.37")	143 (5.63")	R10 (0.39")	13.5 (0.53")	89 (3.50")	22 (0.87")	16 (0.63")	16 (0.63")	13 (0.51")	155 (6.10")	279.5 (11.00")	M16X2	160 (6.30")	156.5 (6.17")	126.5 (4.98")	323 (12.72")	75 (2.95")	12.7 (0.50")	TBD
FKL 250	279 (10.98")	99 (3.90")	111 (4.37")	143 (5.63")	R10 (0.39")	13.5 (0.53")	89 (3.50")	22 (0.87")	16 (0.63")	16 (0.63")	13 (0.51")	172 (6.77")	333.5 (13.13")	M16X2	162.5 (6.40")	151 (5.95")	144.5 (5.69")	343.5 (13.52")	65 (2.56")	15.9 (0.63")	TBD
FKL 400*	440 (17.32")	125 (4.92")	209.5 (8.25")	241 (9.49")	R13 (0.51")	17 (0.66")	32.5 (1.28")	58 (2.28")	17.5 (0.69")	15.5 (0.61")	22 (0.87")	193 (7.60")	348 (13.70")	M20X2.5	188 (7.40")	172.5 (6.79")	127.5 (5.02")	431 (16.97")	80 (3.15")	19 (0.75")	TBD

* FKL 400 HAS 8 HOLES IN FLANGE

126500644 Rev A

* Models are not available in split gearbox design. Please visit www.fristam.com/usa for original design model drawings.

Rectangular inlet not available on models 15, 20, 25, 580, and 600.

FKL Dimensional Drawing Models: 50–400 Rectangular Inlet

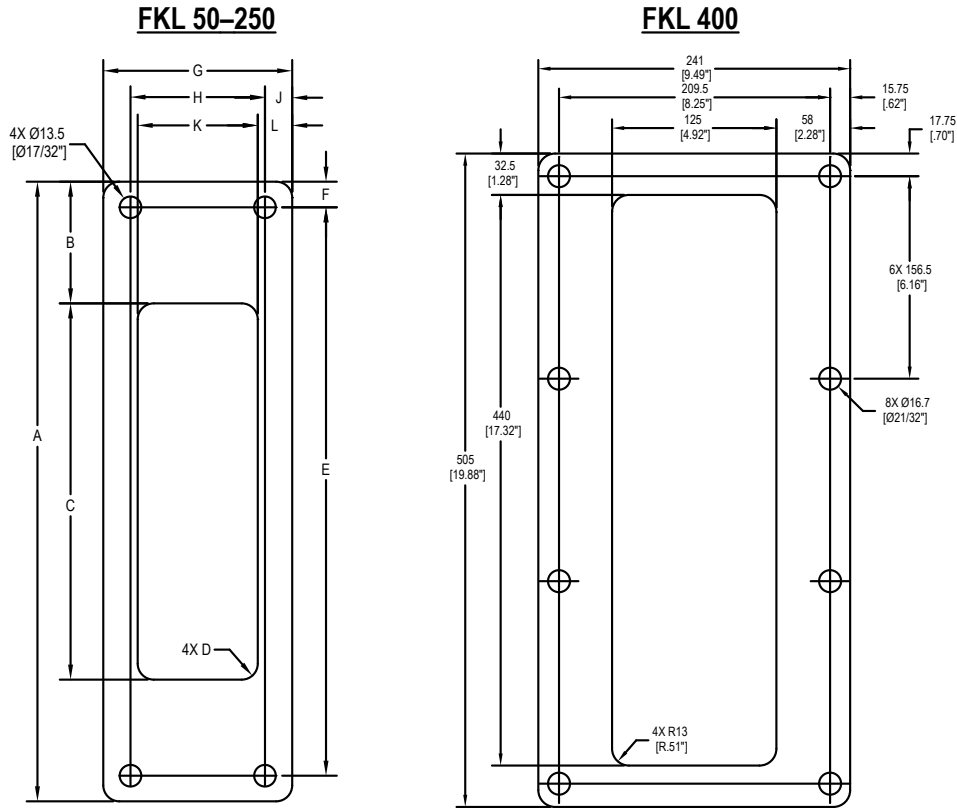

1265000524
Rev C

DIMENSIONS IN MILLIMETERS (INCHES)											
PUMP MODEL	A	B	C	D	E	F	G	H	J	K	L
FKL 50	305 (12.01")	67 (2.64")	171 (6.73")	R6 (0.24"R)	273 (10.75")	16 (0.63")	79 (3.11")	48 (1.89")	15.5 (0.61")	44 (1.73")	17 (0.67")
FKL 75	336 (13.23")	56 (2.20")	224 (8.82")	R10 (0.39"R)	310 (12.20")	13 (0.51")	127 (5.00")	102 (4.02")	13 (0.51")	57 (2.24")	35 (1.38")
FKL 150	387 (15.24")	76 (2.99")	235 (9.25")	R10 (0.39"R)	355 (13.98")	16 (0.63")	143 (5.63")	84 (3.31")	17 (0.67")	75 (2.95")	21.5 (0.85")
FKL 205 & 250	457 (17.99")	89 (3.50")	279 (10.98")	R10 (0.39"R)	425 (16.73")	16 (0.63")	143 (5.63")	111 (4.37")	16 (0.63")	99 (3.90")	22 (0.87")

1265000655
Rev -

* Models are not available in split gearbox design. Please visit www.fristam.com/usa for original design model drawings.
Rectangular inlet not available on models 15, 20, 25, 580, and 600.